

## REDUCED POWER FLIP FLOP DESIGN BASED ON SIGNAL FEED THROUGH SCHEME

Mr. S.Ali Asgar <sup>1</sup>, Dr. P.Krishnamurthy <sup>2</sup>

<sup>1</sup> Assistant Professor, Dept. of ECE, Chadalawada Ramanamma Engineering College, Tirupati

<sup>2</sup> Associate Professor, Dept. of ECE, Chadalawada Ramanamma Engineering College, Tirupati

**Abstract-** Low power has emerged as a principal theme in today's electronics industry. The need for low power has caused a major paradigm shift where power dissipation has become as important a consideration as performance and area. So this Low Power Pulse Triggered Flip Flop reviews various strategies and methodologies for designing low power circuits and systems. It describes the many issues facing designers at architectural, logic, circuit and device levels and presents some of the techniques that have been proposed to overcome these difficulties. The article concludes with the future challenges that must be met to design low power, high performance systems.

In this method an explicit type pulse-triggered structure and a modified true single phase clock latch based on a signal feed-through scheme is used. Pulse-triggered FF (P-FF) is a single-latch structure which is more popular than the conventional transmission gate (TG) and master-slave based FFs in high-speed applications.

**Keywords – Flip-flop (FF), low power, pulse-triggered.**

### I. INTRODUCTION

Flip-flops (FFs) are the basic storage elements used extensively in all kinds of digital designs. In particular, digital designs nowadays often adopt intensive pipelining techniques and employ many FF-rich modules such as register file, shift register, and first in first out. It is also estimated that the power consumption of the clock system, which consists of clock distribution networks and storage elements, is as high as 50% of the total system power. FFs thus contribute a significant portion of the chip area and power consumption to the overall system design [1][2]. Pulse-triggered FF, because of its single-latch structure, is more popular than the conventional transmission gate (TG) and master-slave based FFs in high-speed applications. Besides the speed advantage, its circuit simplicity lowers the power consumption of the clock tree system. A P-FF consists of a pulse generator for strobe signals and a latch for data storage. If the triggering pulses are sufficiently narrow, the latch acts like an edge-triggered FF. Since only one latch, as opposed to two in the conventional master-slave configuration, is needed, a P-FF is simpler in circuit complexity. This leads to a higher toggle rate for high-speed operations [3]-[8]. P-FFs also allow time borrowing across clock cycle boundaries and feature a zero or even negative setup time. Despite these advantages, pulse generation circuitry requires delicate pulse width control to cope with possible variations in process technology and signal distribution network. In a statistical design framework is developed to take these factors into account. To obtain balanced performance among power, delay, and area, design space exploration is also a widely used technique [10]-[13]

In this brief, we present a novel low-power P-FF design based on a signal feed-through scheme. Observing the delay discrepancy in latching data "1" and "0," the design manages to shorten the longer delay by feeding the input signal directly to an internal node of the latch design to speed up the data transition. This mechanism is implemented by introducing a simple pass transistor for extra signal driving. When combined with the pulse generation circuitry, it forms a new P-FF design with enhanced speed and power-delay-product (PDP) performances.

### II. Conventional Explicit Type P-FF Designs

PF-FFs, in terms of pulse generation, can be classified as an implicit or an explicit type. In an implicit type P-FF, the pulse generator is part of the latch design and no explicit pulse signals are generated. In an explicit type P-FF, the pulse generator and the latch are separate [7]. Without generating pulse signals explicitly, implicit type P-FFs are in general more power-economical. However, they suffer from a longer discharging path, which leads to inferior timing characteristics. Explicit pulse generation, on the contrary, incurs more power consumption but the logic separation from the latch design gives the FF design a unique speed advantage. Its power consumption and the circuit complexity can be effectively reduced if one pulse generator is shares a group of FFs. In this brief, we will thus focus on the explicit type P-FF designs only

A.EP-DC

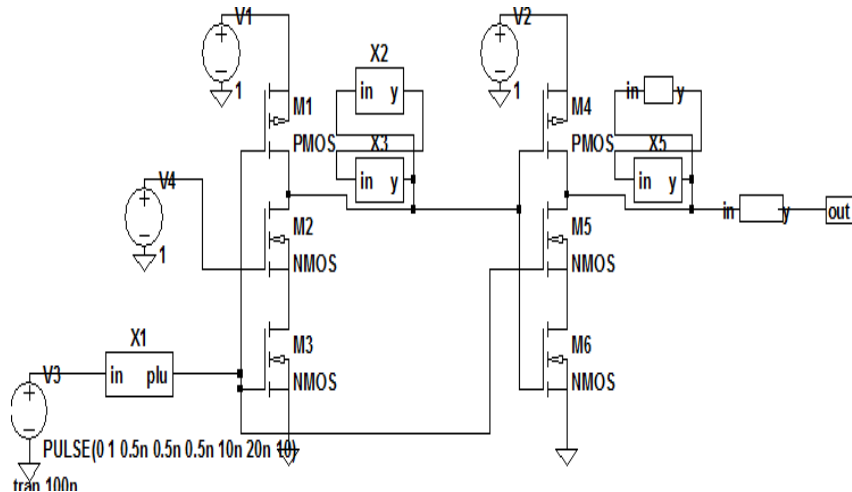

Figure 1(a) Ep-DCO

To provide a comparison, some existing P-FF designs are reviewed first. Fig. 1(a) shows a classic explicit P-FF design, named data-close to- output (ep-DCO) [7]. It contains a NAND-logic-based pulse generator and a semi-dynamic true-single-phase-clock (TSPC) structured latch design. In this P-FF design, inverters I3 and I4 are used to latch data, and inverters I1 and I2 are used to hold the internal node X. The pulse width is determined by the delay of three inverters. This design suffers from a serious drawback, i.e., the internal node X is discharged on every rising edge of the clock in spite of the presence of a static input “1.” This gives rise to large switching power dissipation. To overcome this problem, many remedial measures such as conditional capture, conditional pre charge, conditional discharge, and conditional pulse enhancement scheme have been proposed [14]-[18]

B. CDFP

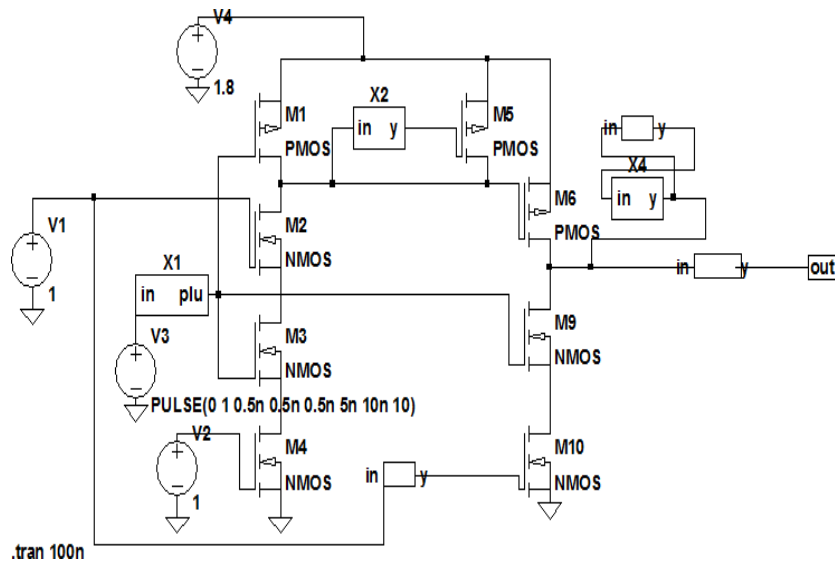
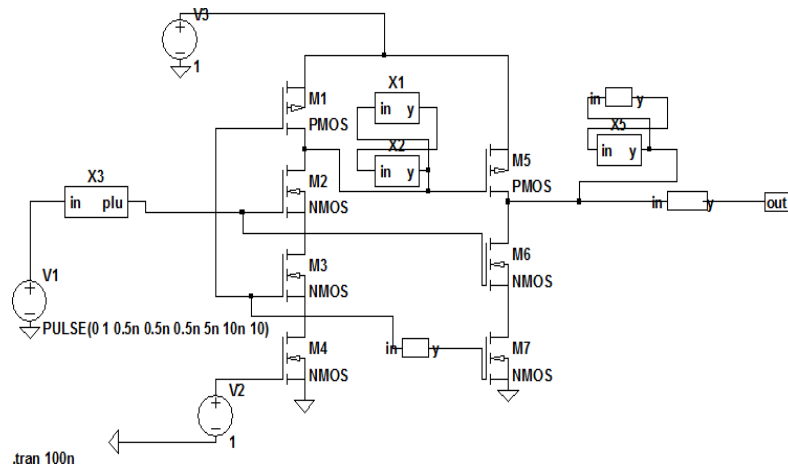

Figure 1(b) Cdfp

Fig. 1(b) shows a conditional discharged (CD) technique [16]. An extra nMOS transistor MN3 controlled by the output signal Q\_fdbk is employed so that no discharge occurs if the input data remains “1.” In addition, the keeper logic for the internal node X is simplified and consists of an inverter plus a pull-up pMOS transistor only

C.STATIC CDFP

Fig. 1(c) shows a similar P-FF design (SCDFP) using a static conditional discharge technique. It differs from the CDFP design in using a static latch structure.



*Figure 1(c) scdff*

Node X is thus exempted from periodical pre charges. It exhibits a longer data-to-Q (D-to-Q) delay than the CDDFF design. Both designs face a worst case delay caused by a discharging path consisting of three stacked transistors, i.e., MN1–MN3. To overcome this delay for better speed performance, a powerful pull-down circuitry is needed, which causes extra layout area and power consumption.

*HLFF*

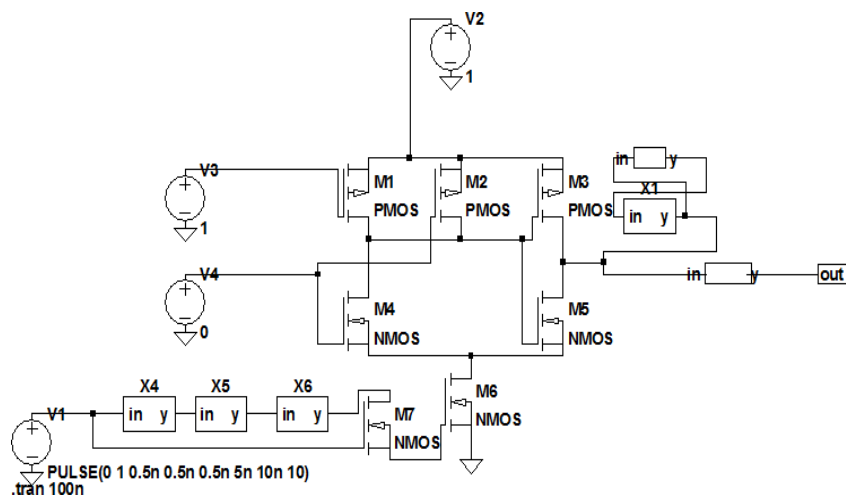

*Figure 1(d)Mhlff*

The modified hybrid latch flip flop (MHLFF) [19] shown in fig. 1(d) also uses a static latch. The keeper logic at node X is removed. A weak pull-up transistor MP1 controlled by the output signal Q maintains the level of node X when Q equals 0. Despite its circuit simplicity, the MHLFF design encounters two drawbacks. First, since node X is not pre discharged, a prolonged 0 to 1 delay is expected. The delay deteriorates further, because a level-degraded clock pulse (deviated by one VT) is applied to the discharging transistor MN3. Second, node X becomes floating in certain cases and its value may drift causing extra dc power [18].

### III Proposed P-FF Design

Recalling the four circuits reviewed in Section 1, they all encounter the same worst case timing occurring at 0 to 1 data transitions. Referring to Fig. 2(a), the proposed design adopts a signal feed-through technique to improve this delay. Similar to the SCDDFF design, the proposed design also employs a static latch structure and a conditional discharge scheme to avoid superfluous switching at an internal node. However, there are three major differences that lead to a unique TSPC latch structure and make the proposed design distinct from the previous one.

First, a weak pull-up pMOS transistor MP1 with gate connected to the ground is used in the first stage of the TSPC latch. This gives rise to a pseudo-nMOS logic style design, and the charge keeper circuit for the internal node X can be saved. In addition to the circuit simplicity, this approach also reduces the load capacitance of node X [20] [21].

Second, a pass transistor MN<sub>x</sub> controlled by the pulse clock is included so that input data can drive node Q of the latch directly (the signal feed-through scheme). Along with the pull-up transistor MP<sub>2</sub> at the second stage inverter of the TSPC latch, this extra passage facilitates auxiliary signal driving from the input source to node Q. The node level can thus be quickly pulled up to shorten the data transition delay.

Third, the pull-down network of the second stage inverter is completely removed. Instead, the newly employed pass transistor MN<sub>x</sub> provides a discharging path. The role played by MN<sub>x</sub> is thus twofold, i.e., providing extra driving to node Q during 0 to 1 data transitions, and discharging node Q during “1” to “0” data transitions. Compared with the latch structure used in SCDF design, the circuit savings of the proposed design include a charge keeper (two inverters), a pull-down network (two nMOS transistors), and a control inverter. The only extra component introduced is an nMOS pass transistor to support signal feedthrough. This scheme actually improves the “0” to “1” delay and thus reduces the disparity between the rise time and the fall time delays. In comparison with other P-FF designs such as ep-DCO, CDFF, and SCDF, the proposed design shows the most balanced delay behaviours.

#### IV Principle of operation

The principles of FF operations of the proposed design are explained as follows. When a clock pulse arrives, if no data transition occurs, i.e., the input data and node Q are at the same level, no current passes through the pass transistor MN<sub>x</sub>, which keeps the input stage of the FF from any driving effort. At the same time, the input data and the output feedback Q<sub>fdbk</sub> assume complementary signal levels and the pull-down path of node X is off.

Therefore, no signal switching occurs in any internal nodes. On the other hand, if a “0” to “1” data transition occurs, node X is discharged to turn on transistor MP<sub>2</sub>, which then pulls node Q high. This corresponds to the worst case timing of the FF operations as the discharging path conducts only for a pulse duration.

However, with the signal feed through scheme, a boost can be obtained from the input source via the pass transistor MN<sub>x</sub> and the delay can be greatly shortened. Although this seems to burden the input source with direct charging/discharging responsibility, which is a common pitfall of all pass transistor logic, the scenario is different in this case because MN<sub>x</sub> conducts only for a very short period. When a “1” to “0” data transition occurs, transistor MN<sub>x</sub> is likewise turned on by the clock pulse and node Q is discharged by the input stage through this route.

Unlike the case of “0” to “1” data transition, the input source bears the sole discharging responsibility. Since MN<sub>x</sub> is turned on for only a short time slot, the loading effect to the input source is not significant. In particular, this discharging does not correspond to the critical path delay and calls for no transistor size tweaking to enhance the speed. In addition, since a keeper logic is placed at node Q, the discharging duty of the input source is lifted once the state of the keeper logic is inverted.

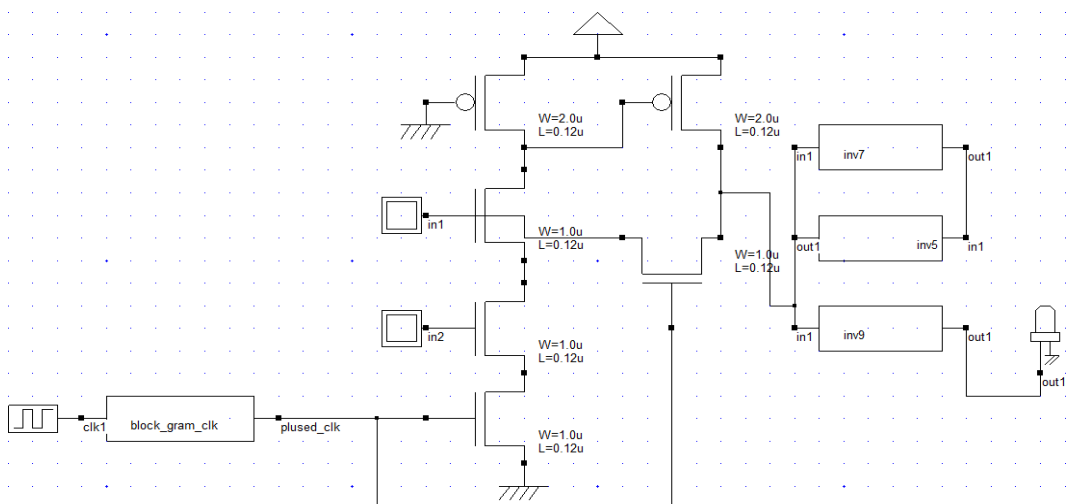

*Figure 2(a) Schematic of the proposed P-FF des*

## V Simulation Results

The target technology is the TSMC 90-nm CMOS process. Since pulse width design is crucial to the correctness of data capture as well as the power consumption [10]-[13], the transistors of the pulse generator logic are sized for a design spec of 120 ps in pulse width in the TT case. The sizing also ensures that the pulse generators can function properly in all input buffer (an inverter) is included. The placed at the output of the clock buffer [18]. Tg condition used in simulations is 500 MHz/1.0 V. Six test patterns, each representing a different data process corners. With regard to the latch structures, each P-FF design is individually optimized subject to the product of power and Dto-Q delay. To mimic the signal rise and fall time delays, input signals are generated through buffers. Since the proposed design requires direct output driving from the input source, for fair comparisons the power consumption of the dataprocess corners. With regard to the latch structures, each P-FF design is individually optimized subject to the product of power and Dto-Q delay. To mimic the signal rise and fall time delays, input signals are generated through buffers. Since the proposed design requires direct output driving from the input source, for fair comparisons the power consumption of the data switching probability, are applied in simulations. Since the proposed signal feed-through scheme requires occasional signal driving from the input node directly to the output node, we also calculate the power drawn by the pass transistor MNx. (the extra power consumption caused by the signal feed through scheme). Post-layout simulation results show that this part accounts for only extra power consumption caused by the signal feed through scheme). Post-layout simulation results show that this part accounts for only switching probability, are applied in simulations. Since the proposed signal feed-through scheme requires occasional signal driving from the input node directly to the output node, we also calculate the power drawn by the pass transistor MNx. (the extra power consumption caused by the signal feed through scheme). Post-layout simulation results show that this part accounts for only.

### A. Power Consumption Performance of FF Designs

Table I summarizes the circuit features and the simulation results. For circuit features, although the proposed design does not use the least number of transistors, it has the smallest layout area. This is mainly attributed to the signal feed-through scheme, which largely reduces the transistor sizes on the discharging path. In terms of power behaviour, the proposed design is the most efficient in five out of the six test patterns. The savings vary in different combinations of test pattern and FF design. Its power saving against ep-DCO, CDFF, SCDF, MHLFF. The ep-DCO design consumes the largest power because of the superfluous internal node discharging problem. The significance of this overhead, however, decreases as the data switching activity increases. A possible concern on the proposed design arises from the pseudo-nMOS logic in the first stage. Although an always-on MP1 prevents node X from a full voltage swing, it does not result in any dc power consumption problem. A full voltage swing can be expected at node Q because of the charge keeper with two inverters employed at node Q. A degraded "0" signal at node X may affect the transition delay of node Q but not the voltage level. The voltage level of node Q remains at an intact value of VDD. Referring to Table II, the leakage power consumption of the proposed design is very close to that of other P-FF designs. The MHLFF design is the one that suffers from a large dc power consumption because of a non full-swing internal node. Its dc (leakage) power consumption is much higher than others and is thus excluded from the comparison [18]. Since the proposed signal feed-through scheme requires occasional signal driving from the input node directly to the output node, we also calculate the power drawn by the pass transistor MNx (the extra power consumption caused by the signal feed through scheme).

### B. Timing Parameters of FF Designs

After the analysis of power performances, we then examine the timing parameters of these FF designs. In this brief, the set-up time is measured as the optimal timing (with respect to the clock edge) of applying input data to minimize the product of power and D-to-Q delay. In other words, its choice is based on the optimization of PDPDQ instead of the D-to-Q delay alone. For most P-FF designs, the minimum PDP values occur at negative setup times. This is because of the extra delay introduced by the pulse generator so that input data can be applied after the triggering edge of the clock. The integration of the pulse generation logic with the latch structure gives SDF an inherent advantage in power consumption.

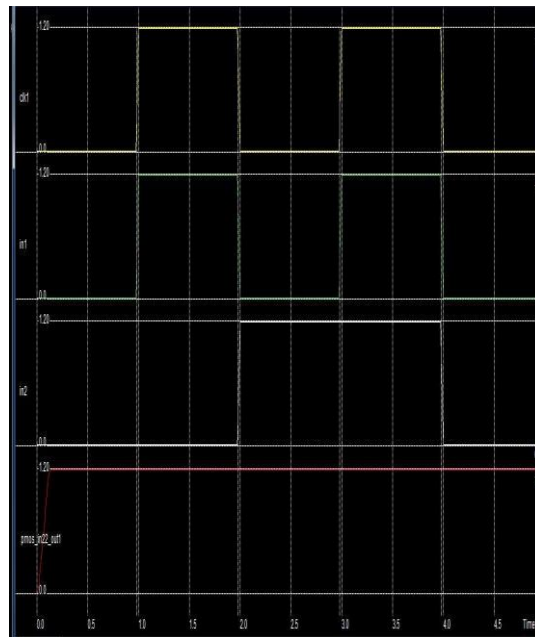

*Figure 3.1. Voltage vs time wave forms*

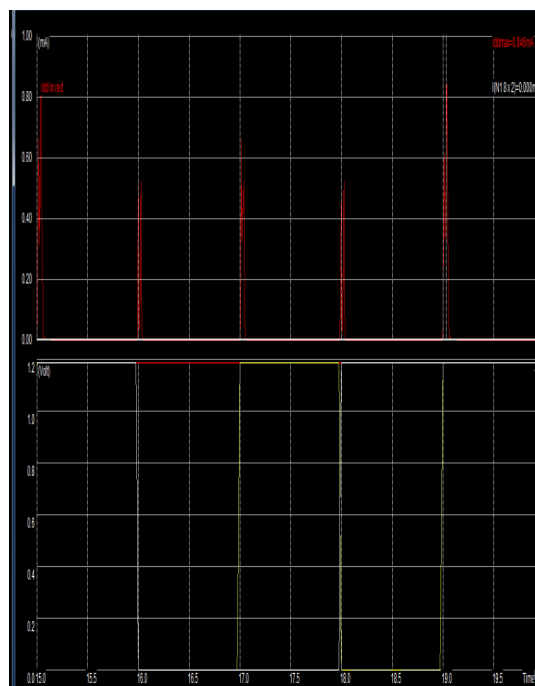

*Figure 3.2 Voltage vs Currents*

FF Designs	ep-DCO	CDFF	SCDFF	MHLFF	Proposed
Number of transistors	28	30	31	19	24
Layout area ( $\mu\text{m}^2$ )	77.86	89.70	89.16	78.94	60.01
Minimum D-to-Q delay (ps)	118.9	129.5	140.0	173.8	106.1
Average power (100% activity) $\mu\text{W}$	34.41	34.08	35.16	31.82	25.03

*Table-1 Feature comparison of various ff designs*

### V. Conclusion

In this brief, we presented a novel P-FF design by employing a modified TSPC latch structure incorporating a mixed design style consisting of a pass transistor and a pseudo-nMOS logic. The key idea was to provide a signal feed through from input source to the internal node of the latch, which would facilitate extra driving to shorten the transition time and enhance both power and speed performance. The design was intelligently achieved by employing a simple pass transistor. Extensive simulations were conducted, and the results did support the claims of the proposed design in various performance aspects.

### REFERENCES

[1] H. Kawaguchi and T. Sakurai, "A reduced clock-swing flip-flop (RCSFF) for 63% power reduction," *IEEE J. Solid-State Circuits*, vol. 33, no. 5, pp. 807–811, May 1998.

[2] K. Chen, "A 77% energy saving 22-transistor single phase clocking Dflip-flop with adoptive-coupling configuration in 40 nm CMOS," in *Proc. IEEE Int. Solid-State Circuits Conf.*, Nov. 2011, pp. 338–339.

[3] E. Consoli, M. Alioto, G. Palumbo, and J. Rabaey, "Conditional pushpull pulsed latch with 726 fJops energy delay product in 65 nm CMOS," in *Proc. IEEE Int. Solid-State Circuits Conf.*, Feb. 2012, pp. 482–483.

[4] H. Partovi, R. Burd, U. Salim, F. Weber, L. DiGregorio, and D. Draper, "Flow-through latch and edge-triggered flip-flop hybrid elements," in *Proc. IEEE Int. Solid-State Circuits Conf.*, Feb. 1996, pp. 138–139.

[5] F. Klass, C. Amir, A. Das, K. Aingaran, C. Truong, R. Wang, A. Mehta, R. Heald, and G. Yee, "A new family of semi-dynamic and dynamic flip-flops with embedded logic for high-performance processors," *IEEE J. Solid-State Circuits*, vol. 34, no. 5, pp. 712–716, May 1999.

[6] V. Stojanovic and V. Oklobdzija, "Comparative analysis of masterslave latches and flip-flops for high-performance and low-power systems," *IEEE J. Solid-State Circuits*, vol. 34, no. 4, pp. 536–548, Apr. 1999.

[7] J. Tschanz, S. Narendra, Z. Chen, S. Borkar, M. Sachdev, and V. De, "Comparative delay and energy of single edge-triggered and dual edge triggered pulsed flip-flops for high-performance microprocessors," in *Proc. ISPLED*, 2001, pp. 207–212.

[8] S. D. Naffziger, G. Colon-Bonet, T. Fischer, R. Riedlinger, T. J. Sullivan, and T. Grutkowski, "The implementation of the Itanium 2 microprocessor," *IEEE J. Solid-State Circuits*, vol. 37, no. 11, pp. 1448–1460, Nov. 2002.

[9] S. Sadrossadat, H. Mostafa, and M. Anis, "Statistical design framework of sub-micron flip-flop circuits considering die-to-die and within-die variations," *IEEE Trans. Semicond. Manuf.*, vol. 24, no. 2, pp. 69–79, Feb. 2011.

[10] M. Alioto, E. Consoli, and G. Palumbo, "General strategies to design nanometer flip-flops in the energy-delay space," *IEEE Trans. Circuits Syst.*, vol. 57, no. 7, pp. 1583–1596, Jul. 2010.

[11] M. Alioto, E. Consoli, and G. Palumbo, "Flip-flop energy/performance versus Clock Slope and impact on the clock network design," *IEEE Trans. Circuits Syst.*, vol. 57, no. 6, pp. 1273–1286, Jun. 2010.

[12] M. Alioto, E. Consoli, and G. Palumbo, "Analysis and comparison in the energy-delay-area domain of nanometer CMOS flip-flops: Part I - methodology and design strategies," *IEEE Trans. Very Large Scale Integr. (VLSI) Syst.*, vol. 19, no. 5, pp. 725–736, May 2011.

[13] M. Alioto, E. Consoli and G. Palumbo, "Analysis and comparison in the energy-delay-area domain of nanometer CMOS flip-flops: Part II - results and figures of merit," *IEEE Trans. Very Large Scale Integr. (VLSI)*

*Syst.*, vol. 19, no. 5, pp. 737–750, May 2011.

[14] B. Kong, S. Kim, and Y. Jun, “Conditional-capture flip-flop for statistical power reduction,” *IEEE J. Solid-State Circuits*, vol. 36, no. 8, pp. 1263–1271, Aug. 2001.

[15] N. Nedovic, M. Aleksic, and V. G. Oklobdzija, “Conditional precharge techniques for power-efficient dual-edge clocking,” in *Proc. Int. Symp. Low-Power Electron. Design*, Aug. 2002, pp. 56–59.

[16] P. Zhao, T. Darwish, and M. Bayoumi, “High-performance and low power conditional discharge flip-flop,” *IEEE Trans. Very Large Scale Integr. (VLSI) Syst.*, vol. 12, no. 5, pp. 477–484, May 2004.

[17] M.-W. Phyu, W.-L. Goh, and K.-S. Yeo, “A low-power static dual edge triggered flip-flop using an output-controlled discharge configuration,” in *Proc. IEEE Int. Symp. Circuits Syst.*, May 2005, pp. 2429–2432.

[18] Y.-T. Hwang, J.-F. Lin, and M.-H. Sheu, “Low power pulse triggered flip-flop design with conditional pulse, Tirupati(A.P), and India.