

# INTEGRATED COOLWARM JACKET

1<sup>st</sup> ROSHAN KUMAR D

*Electronics and  
Communication Engineering  
Paavai Engineering College  
Namakkal, TN, India*  
[roshankumarprsk@gmail.com](mailto:roshankumarprsk@gmail.com)

2<sup>nd</sup> Mr. S. SATHISH

*M.E., MBA., MSW.,  
M.A(Psy.), (Ph.D.),  
Assistant Professor  
Electronics and  
Communication Engineering  
Paavai Engineering College  
Namakkal, TN, India*  
[sathish333@gmail.com](mailto:sathish333@gmail.com)

3<sup>rd</sup> PRAVEEN K

*Electronics and  
Communication Engineering  
Paavai Engineering College  
Namakkal, TN, India*  
[praveenkrish712@gmail.com](mailto:praveenkrish712@gmail.com)

4<sup>th</sup> SANTHOSH P

*Electronics and  
Communication Engineering  
Paavai Engineering College  
Namakkal, TN, India*  
[sansanthosh210@gmail.com](mailto:sansanthosh210@gmail.com)

**Abstract - The Integrated Cool Warm Jacket represents a wearable technology, which seeks to give consumers with a personalized and adaptable comfort experience. In response to the challenges posed by varying environmental conditions, this innovative jacket seamlessly integrates intelligent heating and cooling elements to maintain an optimal body temperature. Equipped with Arduino UNO, Peltier module, Bluetooth module, Lithium ion Battery, Relay, Temperature sensor, LCD display, User Interference with fabric insulation materials. The jacket's design incorporates a network of embedded sensors that continuously monitor ambient temperature, humidity levels, and the wearer's body temperature. These sensors relay real-time data to a control unit, which employs sophisticated algorithms to analyse and interpret the information. Based on the analysis, the system dynamically adjusts the jacket's thermal features, ensuring the wearer remains comfortable in any environment. The integration of these features allows for a fine-tuned balance, offering users a customizable and responsive thermal management system.**

**Keywords – Arduino UNO, Bluetooth module, lithium ion battery, LCD display, Peltier module, Relay, Temperature sensor, User Interface, Fabric and insulation material.**

## I. INTRODUCTION

The Integrated Cool Warm Jacket stands at the forefront of innovation in wearable technology, redefining the concept of personal comfort in changing climates. This suit seamlessly integrates smart textiles with heating and cooling elements, offering users dynamic and personalized thermal experience. Equipped with advanced sensors that monitor ambient temperature, humidity, and the wearer's body temperature in real-time, the jacket's control unit employs sophisticated algorithms to adjust heating and cooling elements accordingly. This intelligent system ensures optimal comfort, addressing individual preferences and environmental demands. This coupled with a user-friendly

control via mobile application. The Integrated Cool Warm Jacket marks a significant leap in the evolution of smart apparel, promising unparalleled adaptability and control over one's thermal well-being in various scenarios, from outdoor activities to everyday wear.

## II. LITERATURE REVIEW

The system is a battery powered heating/cooling suit, wherein the suit's integrated controls and thermo-electric gadgets allow the user to regulate the temperature. The reason for starting this project is that such a suit is practical and beneficial. Our ultimate goal was to create a body suit that was comfortable, easy to put on, and had sufficient controls so that any user could use it as needed.[1]. This system is more handy because it is lighter, smaller, and uses less electricity. We can wear this jacket in both seasons like summer and winter. Instead of using a standard battery, we employ a lithium-ion battery, because the lithium-ion battery has a higher charging and discharging rate. This enables soldiers to perform their duties even in the most severe weather.. This jacket is very efficient, inexpensive, and simple for use with Internet of Things applications.[10].

The jacket is to provide cooling mechanism. The thermoelectric cooler is used to chill water in the reservoir. The line tube in the chilled jacket absorbs body heat. The liquid in lined tube is passed through expansion valve, then pressure of liquid reduces. This liquid is then transferred to the fluid reservoir. Thermoelectric cooler is used to absorb heat from liquid stored in reservoir and transfer to the atmosphere, which causes the liquid held in the reservoir to cool, and vice versa [4]. A design that combines a thermoelectric cooler with a copper box has been developed to improve the heat-exchanging process' efficiency. In this design, liquid refrigerant absorbs heat energy and turns into vapor. Thermoelectric module devices that are readily available for purchase can be installed as forceful heat exchangers in copper boxes[6].

This designed garment is highly useful and necessary for our soldiers as well as other persons who suffer from extreme heat or cold weather. It should maintain our body temperature. It can detect the heart beat and blood pressure [7].

Its basic concept for applying Peltier elements for cell cooling is to use the cool side of the elements to cool a relatively large block of aluminium to the desired temperature. Using the Peltier effect, a cooling device for cell suspensions in flow cytometry has been developed. This prototype can maintain a temperature of 2–5°C in a cell solution up to 3 ml and is used to chill collection tubes during long-duration cell sorting. Consequently, offering an ideal thermal coupling [2].

The working concept in the system is the Peltier effect which produces both heating and cooling effect. This phenomena can be employed if heat needs to be transported on a tiny scale between media. Although heating or cooling can be achieved, cooling is the main usage. As a result, it has temperature control capabilities. With the main focus being on the Peltier effect, a heat exchanger jacket is created to regulate body temperature within comfortable bounds. [5]. At a place where supply of electricity is not available at all things considered, regular air conditioners cannot be used in these conditions; however, thermoelectric jackets may. Wearable devices can be used without the necessity for professional installation, unlike traditional air conditioning systems that require it before use. [3].

When electrical current passes through two dissimilar conductors, the Peltier effect takes place; the junction of the two conductors will either release or absorb heat, depending on which way the current is flowing. Because semiconductors can be more easily tailored for pumping heat, they are the material of choice in thermoelectric technology for producing (typically Bismuth Telluride)[8]. The SAM Jacket maintains the optimum temperature of 20°C automatically. It may also manually set the ideal temperature if the user so chooses. The user wishes to enter data using a mobile phone that is connected to a Bluetooth module if they wish the temperature to be lower or higher than the ideal temperature.[9].

**III. PROPOSED METHODOLOGY**

The Integrated Cool Warm Jacket stands at the forefront of innovation in wearable technology, redefining the concept of personal comfort in changing climates. This suit seamlessly integrates smart textiles with heating and cooling elements, offering users a dynamic and personalized thermal experience. Equipped with advanced sensors that monitor ambient temperature, humidity, and the wearer's body temperature in real-time, the jacket's control unit employs sophisticated algorithms to adjust heating and cooling elements accordingly. This intelligent system ensures optimal comfort, flexibility addressing individual preferences and environmental demands. The sleek and ergonomic design, coupled with user-friendly controls via a

mobile application, exemplifies a harmonious convergence-fashion and technology. This groundbreaking technology has the potential to revolutionize various industries, including outdoor recreation, sports, and healthcare, where it's essential to maintain an ideal body temperature for both wellbeing and performance. The Integrated Cool Warm Jacket marks a significant leap in the evolution of smart apparel, promising unparalleled adaptability and control over one's thermal well-being in various scenarios, from outdoor activities to everyday wear.

Hardware Components used in this project is Arduino UNO act as the brain of the system, handling control and communication. Bluetooth Module HC-05 Provides wireless communication with the mobile app. Peltier Module includes both heating and cooling condition. Sensors like temperature sensors or humidity sensors for detecting climate variations. Mobile Device (Android or iOS)The user's smartphone or tablet, which runs the mobile.

The Arduino IDE software was one of the software components used in this project. The Arduino UNO's operating system responsible for Temperature sensor, Peltier module and Bluetooth communication. Developed in a language like Python. Mobile App for Android that allows users to control the temperature via Bluetooth. It allows the wearer to manually controlled or automatically control the jacket's settings.

System Functionalites are the mobile app establishes a Bluetooth connection with the Arduino UNO. Users can control the temperature using the app, issuing commands to change the Celsius The insulating materials and outside fabric are selected based on their longevity, adaptability, and capacity to function with the integrated components while maintaining comfort levels .Fig 1 shows the schematic diagram of the project.

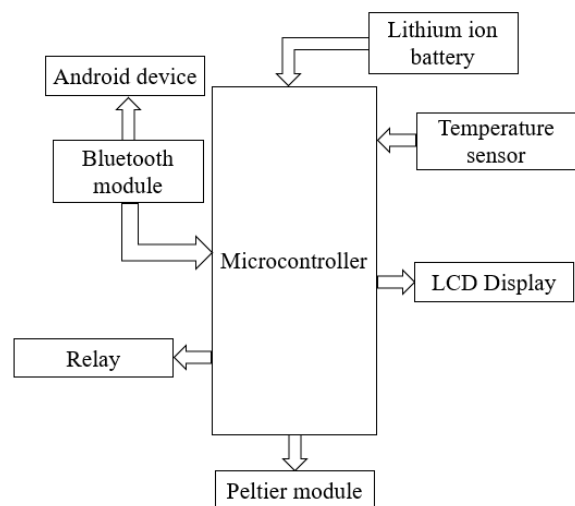

**FIGURE 1. SCHEMATIC DIAGRAM OF THE INTEGRATED COOLWARM JACKET**

### A. *Arduino Uno*

A microcontroller board called Arduino or Arduino Uno is built around the ATmega328P. Six analog inputs, There are fourteen digital input/output pins total six of which can be utilized as PWM outputs as well as a 16 MHz quartz crystal, a reset button, an ICSP header, a power jack, and a USB port.. It contains everything needed to support the microcontroller To begin, just use a USB cord to connect it to a computer, and either an AC-to-DC adapter or a battery will provide power. The Arduino platform's reference model and the first in a line of USB Arduino boards is the Uno board. For a complete list of all boards past, present, and out-of-date visit the Arduino index of boards. The Arduino index of boards contains a comprehensive list of all previous and current Arduino boards as well as the platform and the Uno board.

### B. *Lithium ion Battery*

An Lithium-ion (Li-ion) batteries are extensively utilized in a wide range of electronic products because of their rechargeable nature, high energy density, and comparatively lightweight construction. The primary function of a lithium-ion battery is to store and provide electrical energy for electronic devices During the charging and discharging processes, lithium ions travel between the positive (cathode) and negative (anode) electrodes.

The main function of a lithium-ion battery is to store electrical energy chemically Because lithium-ion batteries are rechargeable, they can be used repeatedly by applying an external electrical current during the charging process to reverse the electrochemical reactions. Lithium-ion batteries often support rapid charging, allowing electronic devices to be charged quickly. Nevertheless, the rate of charging could differ based on the particular battery and gadget. It is manageable in size and versatile. Rapid charging is frequently supported by lithium-ion batteries, which makes it possible to fast charge electronic gadgets. It power the lives of millions of people each day. It restore the normal capacity.

Lithium-ion batteries typically provide a stable voltage throughout most of their discharge cycle, ensuring consistent power delivery to electronic devices until the battery is nearly depleted Li-ion batteries have a high energy density, which allows them to store a lot of energy in a relatively small and light package. They are therefore appropriate for use with portable electronics.

### C. *Relay*

A relay is a switch that is powered by electricity. Current flowing through the relay's coil creates a magnetic field that modifies the switch contacts by pulling a lever. Relays have two switch positions and are double throw (changeover) switches because they allow the coil current to be turned on or off conditions. It permits small amount of electrical current to control. For example Relays can be used in low voltage battery circuits to switch 230V AC

mains circuit. The relay's magnetic and mechanical link between the two circuits is the only internal electrical connection. Relays that are intended to run at lower voltages can have coil currents as high as 100mA, while for 12V relays, the common coil current is 30mA. Since most integrated circuits (ICs) are unable to supply this current, a transistor is typically needed to increase the little IC current to the higher value needed for the relay coil. Since the well-known 555 timer IC has a maximum output current of 200mA, these devices can power relay coils directly—without the need for amplification. The relay is DPDT because there is one set of contacts (SPDT) in the foreground and another behind them.

### D. *Bluetooth Module*

The HC-05 is a popular Bluetooth module that is commonly used for wireless communication in various electronic projects. Its primary function is to enable Bluetooth communication between devices. The HC-05 module facilitates wireless communication between electronic devices using the Bluetooth protocol. It establishes a communication link between a host (e.g., microcontroller, Arduino, Raspberry Pi) and other devices like smartphones, tablets, or other Bluetooth-enabled modules. The HC-05 module is often used to establish a serial communication link (UART) between devices. It allows for the transmission and reception of serial data wirelessly, making it useful for projects that require cable-free data exchange.

### E. *Temperature Sensor*

A common precision temperature sensor in electronic projects and applications is the LM35. Its primary function is to measure ambient temperature. Because of its low power consumption, it is appropriate for systems that are energy-efficient and battery-powered. The LM35 is easy to interface with microcontroller.

The degree of hotness of the body which is a measure of heat content in the body is known as temperature. Temperature sensor is a device that measures the hotness or coolness of an object and produces an electrical signal with respect to the measured temperature. LM35 can be used to measure the internal temperature. It has an electrical output proportional to the measured temperature in Celsius.

### F. *Peltier Module*

The TEC1-12706 is a type of Peltier module, which is a thermoelectric device that can be used for both cooling and heating applications. The primary function of the TEC1-12706 module is to provide thermoelectric cooling.

While commonly used for cooling, the TEC1-12706 can also function as a heater. By reversing the direction of the electric current, the module's sides switch roles, with the previously cooler side now becoming the warmer side. The TEC1-12706 operates based on the Peltier effect which involves the absorption or release of heat at the

intersection of two distinct conductors in the presence of an applied electric current. The TEC1-12706 operates without any moving parts, as it is a solid-state device. This makes it more reliable and requires less maintenance.

### G. LCD Display

A common form of flat-panel display technology used in electrical devices to produce visual output is liquid crystal display (LCD). Presenting information visually is an LCD display's primary purpose.

The primary function of an LCD display is to visually present information to the user. This information can include text, numbers, graphics, or a combination of these elements. LCDs are commonly used to display textual information. They can show messages, prompts, and data in a readable and organized format. LCDs can display real-time information, making them suitable for applications where dynamic and constantly changing data need to be presented, such as stock prices, weather updates, or live feeds. It providing a means for users to interact with the device by presenting menus, options, and feedback.

### I. Arduino Software (IDE)

Arduino IDE is an open-source software designed for coding and compiling code into Arduino Modules. As the official Arduino software, it simplifies code compilation, enabling even people without technological knowledge to access it. The Java Platform-based IDE is compatible with MAC, Windows, and Linux. It provides integrated features that are essential for debugging, editing, and code compilation.. Various Arduino modules, such as Uno, Mega, and Leonardo, are available. The IDE's primary components include the Editor for code creation and the Compiler for code compilation and upload to the Arduino Module. The generated Hex File from the main code, known as a sketch, is uploaded to the board's controller.

The IDE environment consists of two essential parts: the Editor for code creation and the Compiler for code compilation and upload to the Arduino Module. The resulting Hex File from the main code, or sketch, is transferred and uploaded to the board's controller.

The Arduino Software (IDE) operates on the concept of a sketchbook, providing a standardized location to store programs. Sketches can be accessed from the File > Sketchbook menu or the Open button on the toolbar. Upon the first run of the Arduino software, a directory for the sketchbook is automatically created.

## IV. RESULT

The Integrated Cool Warm Jacket project has yielded exceptional results, showcasing a wearable technology and functional design. Through meticulous integration of temperature sensors, heating/cooling elements

the jacket delivers a personalized thermal experience, adapting seamlessly to diverse environmental conditions.

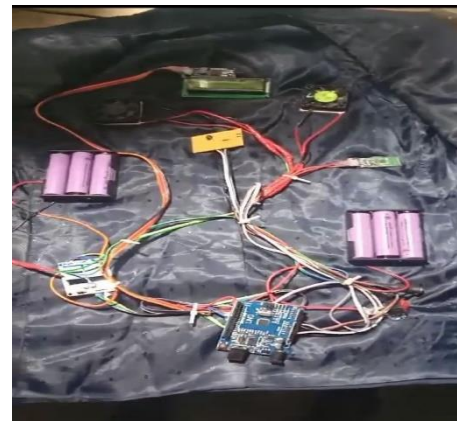

**Figure 2.** Prototype Jacket

## V. CONCLUSION

In conclusion, the Integrated Cool Warm Jacket combines advanced temperature sensors, heating, and cooling elements, the jacket provides users with a customizable and responsive thermal experience. It also sets a precedent for the integration of intelligent features in clothing. Through user-friendly controls and rigorous testing, the project has a seamless convergence of fashion and technology.

## ACKNOWLEDGMENT

We would like to show our gratitude to the Paavai Engineering College and thank staff of Department of ECE. And we sincerely thank our parents.

## REFERENCES

1. Battery Powered Heating and Cooling Suit, Gregory Paul and Edward Gim, David Westerfeld Department of Electrical and Computer Engineering State University of New York at Stony Brook Stony Brook, NY 11794,2014
2. Cell-Cooling in Flow Cytometry by Peltier Elements, Christopher Gottlinger, Klaus L. Meyer, Walter Weichel, Werner Muller, Brian Kaftery, and Andreas Radbruch Institute for Genetics, University of Cologne, Weyertal 121, D-5000-Koln 41, Federal Republic of Germany.
3. Comparison Between Traditional Air Conditioning System and Wearable Cooling/Heating Devices”, Mohd Bilal Laique, Department of Mechanical Engineering, JSS Academy of Technical Education, Noida, India, International Journal of Engineering Research & Technology (IJERT) ISSN:2278-0181 Vol. 7 Issue 09, September-2018.

4. Cooling and Heating of Refrigerator Jacket by Using Peltier Effect, G. Lavanya, P.G. Research Scholar, Department of Mechanical Engineering, J.N.T.U.A College of Engineering, Ananthapuram-515001, Andhra Pradesh, India, Volume 01 Issue 01
5. Design and fabrication of body heat balance jacket, Rohit Nandan, Pranveer Singh Institute of Technology, Kanpur, Uttar Pradesh, International Journal of Advance Research, Ideas and Innovations in Technology, ISSN:2454-132X Impact factor:4.295
6. Gunathilake Banda Delkumburewatte & Tilak Dias(2012), Wearable cooling system to manage heat in protective clothing, The Journal of The Textile Institute,103:5,483-489
7. ISSN:2321-9653; Volume 10 Issue, Advanced Jacket for Military Defense and Social Welfare, Prof. T.H. Mohite, J.J. Magdum College of Engineering, Maharashtra, India.
8. Peltier Thermoelectric Cooling Module, Global Journal for Research Analysis, Ankur Mishra IIMT College of Engineering, Greater Noida, ISSN:2277-8160 Volume-7, Issue-2 Feb-2018.
9. SAM- The Smart Adaptable Management Jacket, Swetha.T.N Assistant Professor, Department of ECE, SJC Institute of Technology, Chickaballapur-562101, India.
10. Smart Jacket Based on IOT Review, Dhanaji Sugriv Narwade Trinity Academy of Engineering, Pune, Maharashtra International Journal of Advance Research, Ideas and Innovative in Technology, ISSN:2454-132X (Volume 5, Issue 3)